

General Information	Documentation A full set of operation and maintenance manuals and circuit wiring diagrams.
	Generating Set Standards The equipment meets the following standards: BS5000, ISO 8528, ISO 3046, IEC 60034, Sterling Generators is a fully accredited ISO 9001:2008, ISO14001:2004, and BS OHSAS 18001:2007 company.
	Warranty 18 months from the date of dispatch from factory or 12 months from the date of commissioning of the set at site which ever occurs first for manufacturing defects or poor workmanship limited to metal parts only. For more details please refer our warranty manual.



Sterling and Wilson Powergen Pvt. Ltd.

Regional Offices

Bangalore
Sterling & Wilson Powergen Pvt. Ltd.
4A/14, 4th Main, Chikka Adugodi New Extension, Thavarekere Main Road, Bengaluru-560 029.
Tel: 080 67178601-09, Fax: 080 67178675, Email: dgbangalore@sterlingwilsonpowergen.com

Kolkata
Sterling & Wilson Powergen Pvt. Ltd.
3rd Floor, Benfish IT Tower, Plot G.N. 31, Sector V, Salt Lake City, Kolkata-700 091.
Tel: 033 30118100, Fax: 033 30118159, Email: dgkolkata@sterlingwilsonpowergen.com

Mumbai
Sterling & Wilson Powergen Pvt. Ltd.
10th Floor, Universal Majestic Building, P.L. Lokhande Marg, Chembur (West), Mumbai-400 043.
Tel: 022 25526100, Fax: 022 25526200, Email: dgmumbai@sterlingwilsonpowergen.com

Noida
Sterling & Wilson Powergen Pvt. Ltd.
A-7, Sector-6, Ground Floor, Noida-201 301 (UP).
Tel: 120 4515600, Fax: 120 4515610, Email: dgdelhi@sterlingwilsonpowergen.com

Branch Offices

Ahmedabad
Sterling and Wilson Powergen Pvt. Ltd.
3rd Floor, Camps Corner 2, Opp. Prahlanagar Garden, Satellite, Ahmedabad-380015.
Cell No.: 09327009805

Chennai
Sterling and Wilson Powergen Pvt. Ltd.
No.41, B & C, Guindy Industrial Estate, Ekkattuthangal, Chennai-600 097.
Tel: 044 42956666
Fax: 044 22253918

Cochin
Sterling And Wilson Powergen Pvt. Ltd.
23/500E, Kallupurackal Centre, Unichira, Changampuzha Nagar Post, Cochin-628033.
Cell No.: 9961942909

Hyderabad
Sterling and Wilson Powergen Pvt. Ltd.
No.8-2-596-6, Survey no.-118/119, Near Karvey, Road No.10, Banjara Hills, Shekpet Village, Hyderabad-500034.
Tel: 040 23141000-04
Fax: 040 23141001

Pune
Sterling and Wilson Powergen Pvt. Ltd.
3rd Floor, Signet Corner, Opp. Orchid School, Balewadi Naka, Baner, Pune-411 045.
Tel: 020 2729 3156 / 57 / 58

Vadodara
Sterling and Wilson Powergen Pvt. Ltd.
301 Sudhan Apartments, Near Tejas Vidyalaya, Ellora Park, Vadodara-390 023.
Tel: 0265 3057211
Fax: 0265 2386756

Sterling and Wilson Powergen Pvt. Ltd.

Corp. Office : 10th Floor, Universal Majestic Building, P.L. Lokhande Marg, Chembur (West), Mumbai - 400 088.

Tel: +91-022-2552 6100 Fax: +91-022-2552 6200. dgmumbai@sterlingwilsonpowergen.com

Regd. Office : B-2 Bussa Udyog Bhavan, T.J. Road, Sewri West, Mumbai - 400 015

Factory : Survey No.: 59, 343/1, Village Kala, Kherdi, Khanvel, Silvassa, UT of Dadra & Nagar Haveli

Diesel Genset Model SGM 275 PR



Output Ratings	Generating Set Rating	Prime power		Ratings & Performance Data	Engine Make & Model	MTU - 6R1600G10F
	415V @ 50 Hz	275 KVA	220 kW		Alternator Make & Model	Leroy Somer - LSC 45 M2
	Note: Ratings at 0.8 power factor.				Base Frame	SGPL
	Definitions:				Frequency	50 Hz
	Prime Rating				Engine Speed	1500 RPM
	This rating is applicable for supplying continuous electrical power (at variable load) in lieu of commercially purchased power. 10% overload capacity is available for one (01) hour in every twelve (12) hours of operation. Average load factor should not exceed 75%.				Fuel Tank Capacity	758 Liters
Fuel Consumption Data			Rated Current	382.25 Amps.		
Fuel consumption data with diesel fuel with specific gravity of 0.85 and conforming to IS: 1460			Ratings in accordance with ISO 8528, ISO 3046, IEC 60034, BS 5000. Accessories shown many not be part of standard Generating Set			

Standard Features	The MTU Range	
	<ul style="list-style-type: none"> Sterling provides a range of MTU engine powered generating sets which are globally recognised for reliability. Global technology available in India. Most energy efficient D. G. set in its own rating. Micro processor based control system. Wider maintenance intervals. Pre tested at factory with PLC test bench. Well experienced and trained engineers for 24 x 7 after sales support. Designed to meet the latest environmental norms and approved by CPCB nodal agency. 	

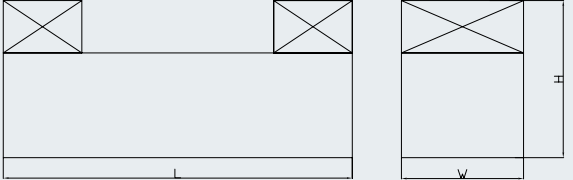
Layout			Dimensions & Weights	Length = L	mm	5500
	SGPL/MECH/SGM/SS/001			Width = w	mm	2000
Height = H			mm	3050		
Dry Weight			kg	6800		
Wet Weight			kg	7000		
Transient performance corresponds to ISO 8528 - 5, Class						

Engine Technical Data	No. of Cylinders/Alignment:	6 / In line	Induction System	Air Filter Type:	Dry type
	Cycle:	4 - Stroke		Combustion Air Flow:	0.3 m ³ /s
	Bore / Stroke: mm	122x150			
	Aspiration	Turbo Charged, Aftercooled		Air Intake Restriction	50 mbar
	Cooling Method:	Radiator			
	Governing Type:	Electronic, Isochronous, Droop adj. to 4%			
	Governing Class:	As per ISO 8528, Ch. 5, better than class G3		Displacement: L	10.5

Cooling System	Cooling System Capacity: L	40+45	Lubrication System	Oil Filter Type:	paper element
	Water Pump Type:	Engine driven		Total Oil Capacity: L	46
	Radiator Fan Load:	9.8 kW		Oil Type:	15W40 API - CH4 -CI4
	Radiator Cooling Airflow:	6.2 m ³ /s		Lub. Oil Consumption:	% of B < 0.2 -0.5

Fuel System	Fuel Filter Type	Spin on type with paper element			Exhaust System	Silencer Type	Critical-grade	
	Recommended Fuel	HSD (IS 1460)				Silencer Model & Quantity	1 No.	
	Fuel Consumption : L/hr					Maximum Allowable Back Pressure	85-150 mbar	
		Prime	50%	75%		100%	Exhaust Gas Flow	0.9 m ³ /s
		Load	Load	Load		Load	Exhaust Gas Temperature	495 °C
					30.03	43.3	56.86	
*Note: Specific gravity of fuel considered - 850 gms/Litre with 5% tolerance								

Alternator Physical Data	Make	LEROY SOMER	Alternator Operating Data	Overspeed:	1800
	Model	LSC 45M2		Voltage Regulation:	±1%
	No. of Bearings	1		Voltage	415V
	Insulation Class	H		Short Circuit Ratio	0.48
	Ingress Protection Rating	IP 23		% Reactances (full load)	
	Excitation System	SHUNT			Xd 2.683
	AVR Type	R-238			X'd 0.122
			X"d 0.093		

Controller Standard Supply	SG 1001 :		Controller Optional Supply	SG 2001 :	
	Standard Supply			Optional	
	Features			Features	
	Start/Stop			Start/Stop	
	Local and Remote Start/Stop			Local and Remote Start/Stop	
	Generator Set Breaker Control			Mains Monitoring	
	Easily Accessible			Generator Set Breaker Control	
				Main Breaker Control	
				Easily Accessible	
	Display			Display	
	Engine Parameters:			Engine Parameters:	
		RPM			RPM
		Oil Pressure			Oil Pressure
		Coolant Temperature			Coolant Temperature
		Hour Meter			Hour Meter
		Battery Volts			Battery Volts
		fuel consumption			fuel consumption
	Running Status			Running Status	
	Event Recording			Event Recording	
	Electrical Parameters			Electrical Parameters	
	Voltage, Current, Hz, kVA, PF, kWh, kW and kVAR			Voltage, Current, Hz, kVA, PF, kWh, kW and kVAR	
	Genset Breaker Status			Breaker Status	
	Engine Protection			Engine Protection	
	High Water Temperature			High Water Temperature	
	Low Lube Oil Pressure			Low Lube Oil Pressure	
	Engine Over speed Shutdown			Engine Over speed Shutdown	
	Electrical Protection			Electrical Protection	
kW Overload		kW Overload			
Unbalanced Load		Unbalanced Load			
Under/Over Voltage		Under/Over Voltage			
Under/Over Frequency		Under/Over Frequency			
Over Current Protection		Over Current Protection			
Revers power protection		Revers power protection			
modbus communication for BMS		modbus communication for BMS			
Panel location: Right side of the canopy viewing from Alternator end.					